

PI550A-S Series

Special Solar Inverter For Water Pump

English Manual

1. Foreword

Thank you for choosing PI550A-S series basic special solar inverter for water pump.

The diagram of operating manual ,Maybe slightly different from the product for convenience of explanation. Due to product upgrades, they may be slightly different also. Please refer to the actual product.

The end-users should hold this manual, and keep it well for future maintenance & care .

For any problem within the warranty period, please fill out the warranty card and fix it to our authorized dealer.

2.Instructions on nameplate

POWTRAN Inverter model	MODEL	PI 550A-S 2R2G3
Output Power Spec.	POWER	2.2kW
Input Source spec.	INPUT	DC 250~800V/AC 3PH 380V
Output Spec.	OUTPUT	AC 3PH 0V~Vin 5.1A 0~400Hz
Bar code		
Production Sequence No.	ZPM1A01SB04G300001	
Production Address	GUANGDONG POWTRAN POWER ELECTRONICS CO.,LTD	

CE



Model Designation:

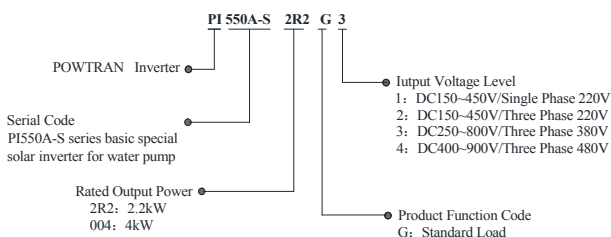

3. Technical specifications

Model	Rated output power(kW)	Rated input current(A)	Rated output current(A)	Adaptive motor power(kW)	Frame No.
AC 1PH220V(-15%)~240V(+10%)					
PI550A-S 0R4G1	0.4	5.4	2.5	0.4	A1
PI550A-S 0R7G1	0.75	8.2	4	0.75	A1
PI550A-S 1R5G1	1.5	14	7	1.5	A2
PI550A-S 2R2G1	2.2	23	10	2.2	A2
PI550A-S 004G1	4	35	16	4	A3
PI550A-S 5R5G1	5.5	50	25	5.5	A4
PI550A-S 7R5G1	7.5	68	32	7.5	A4
PI550A-S 011G1	11	100	45	11	A5
PI550A-S 015G1	15	136	60	15	A6
PI550A-S 018G1	18.5	163	75	18.5	A6
PI550A-S 022G1	22	200	90	22	A8
AC 3PH 220V(-15%)~240V(+10%)					
PI550A-S 0R4G2	0.4	4.1	2.5	0.4	A1
PI550A-S 0R7G2	0.75	5.3	4	0.75	A1
PI550A-S 1R5G2	1.5	8.0	7	1.5	A1
PI550A-S 2R2G2	2.2	11.8	10	2.2	A2
PI550A-S 004G2	4	18.1	16	4	A3
PI550A-S 5R5G2	5.5	28	25	5.5	A3
PI550A-S 7R5G2	7.5	37.1	32	7.5	A4
PI550A-S 011G2	11	49.8	45	11	A4
PI550A-S 015G2	15	65.4	60	15	A5
PI550A-S 018G2	18.5	81.6	75	18.5	A6
PI550A-S 022G2	22	97.7	90	22	A7
AC 3PH 380V(-15%)~440V(+10%)					
PI550A-S 0R7G3	0.75	4.3	2.5	0.75	A1
PI550A-S 1R5G3	1.5	5.0	3.8	1.5	A1
PI550A-S 2R2G3	2.2	5.8	5.1	2.2	A1
PI550A-S 004G3	4	10.5	9	4	A2
PI550A-S 5R5G3	5.5	14.6	13	5.5	A3
PI550A-S 7R5G3	7.5	20.5	17	7.5	A3
PI550A-S 011G3	11	26	25	11	A3
PI550A-S 015G3	15	35	32	15	A4
PI550A-S 018G3	18.5	38.5	37	18.5	A4
PI550A-S 022G3	22	46.5	45	22	A4
AC 3PH 480V±10%					

PI550A-S 0R7G4	0.75	4.1	2.5	0.75	A1
PI550A-S 1R5G4	1.5	4.9	3.7	1.5	A1
PI550A-S 2R2G4	2.2	5.7	5.0	2.2	A1
PI550A-S 004G4	4	9.4	8	4	A2
PI550A-S 5R5G4	5.5	12.5	11	5.5	A3
PI550A-S 7R5G4	7.5	18.3	15	7.5	A3
PI550A-S 011G4	11	23.1	22	11	A3
PI550A-S 015G4	15	29.8	27	15	A4
PI550A-S 018G4	18.5	35.7	34	18.5	A4
PI550A-S 022G4	22	41.7	40	22	A4

4.Dimension

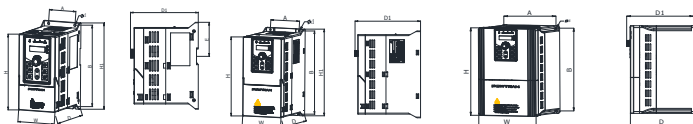

0.75~4kW G3 dimensions

- (supports rail mounting)

5.5~11kW G3 dimensions;

15~22kW G3 dimensions

Model	Output power (kW)	Dimensions(mm)					Installation (mm)			Installation position of guide rail(mm) E	Weight (kg)	Frame No.
		H	H1	W	D	D1	A	B	d			
Outline dimension drawing and installation dimension of single phase 220 V AC												
PI550A-S 0R4G1	0.4	163	185	90	146	154	65	174	5	72.5	1.6	A1
PI550A-S 0R7G1	0.75				146	154	65	174	5			
PI550A-S 1R5G1	1.5				166	174	65	174	5			
PI550A-S 2R2G1	2.2	238	260	120	182	190	90	250	5	/	2.7	A3
PI550A-S 004G1	4				182	190	90	250	5			
PI550A-S 5R5G1	5.5				193	201	155	276	5			
PI550A-S 7R5G1	7.5	290	/	170	193	201	155	276	5	/	5.8	A4
PI550A-S 011G1	11				193	201	155	276	5			
PI550A-S 015G1	15				193	201	155	276	5			
PI550A-S 018G1	18.5	380	400	240	215	223	180	385	7	/	13	A6
PI550A-S 022G1	22				215	223	180	385	7			
PI550A-S 022G1	22				275	283	220	500	10			
Outline dimension drawing and installation dimension of three phase 220 V AC												
PI550A-S 0R4G2	0.4	163	185	90	146	154	65	174	5	72.5	1.6	A1
PI550A-S 0R7G2	0.75				146	154	65	174	5			
PI550A-S 1R5G2	1.5				166	174	65	174	5			
PI550A-S 2R2G2	2.2	238	260	120	182	190	90	250	5	/	2.7	A3
PI550A-S 004G2	4				182	190	90	250	5			
PI550A-S 5R5G2	5.5				193	201	155	276	5			
PI550A-S 7R5G2	7.5	290	/	170	193	201	155	276	5	/	5.8	A4
PI550A-S 011G2	11				193	201	155	276	5			
PI550A-S 015G2	15				193	201	155	276	5			
PI550A-S 018G2	18.5	380	400	240	215	223	180	385	7	/	13	A6
PI550A-S 022G2	22				215	223	180	385	7			
PI550A-S 022G2	22				280	215	223	180	385			
Three phase 380V AC outline dimension drawing and installation dimension												
PI550A-S 0R7G3	0.75	163	185	90	146	154	65	174	5	72.5	1.6	A1
PI550A-S 1R5G3	1.5				146	154	65	174	5			
PI550A-S 2R2G3	2.2				166	174	65	174	5			
PI550A-S 004G3	4	238	260	120	182	190	90	250	5	/	2.7	A3
PI550A-S 5R5G3	5.5				182	190	90	250	5			
PI550A-S 7R5G3	7.5				193	201	155	276	5			
PI550A-S 011G3	11	290	/	170	193	201	155	276	5	/	5.8	A4
PI550A-S 015G3	15				193	201	155	276	5			
PI550A-S 018G3	18.5				193	201	155	276	5			
PI550A-S 022G3	22	215	223	180	385	7	14	A7				
Three phase 480V AC outline dimension drawing and installation dimension												
PI550A-S 0R7G4	0.75	163	185	90	146	154	65	174	5	72.5	1.6	A1
PI550A-S 1R5G4	1.5				146	154	65	174	5			
PI550A-S 2R2G4	2.2				166	174	65	174	5			
PI550A-S 004G4	4	238	260	120	182	190	90	250	5	/	2.7	A3
PI550A-S 5R5G4	5.5				182	190	90	250	5			
PI550A-S 7R5G4	7.5				193	201	155	276	5			
PI550A-S 011G4	11	290	/	170	193	201	155	276	5	/	5.8	A4
PI550A-S 015G4	15				193	201	155	276	5			
PI550A-S 018G4	18.5				193	201	155	276	5			
PI550A-S 022G4	22	215	223	180	385	7	14	A7				

※Note:Recommended DC input power is above 1.2 times of inverter rated power (for 3 phase,380V inverters).

5.Keyboard Description

5.1 Keyboard Indicators

Indicator flag		Name
Status lamp	RUN	Running indicator light *ON: the inverter is working *OFF: the inverter is stops
	LOCAL/REMOTE	Command indicator light ,That is the indicator for keyboard operation, terminal operation and remote operation(communication control) *ON: terminal control working status *OFF: keyboard control working status *Flashing: Remote control working status
	FWD/REV	Forward/reverse running light *ON: in forward status *OFF: in reversal status
	TUNE/TC	Motor self-learning/Torque control/Fault indicator *Slow flashing: in the motor tuning status *Quick flashing: in the fault status



Units Combination indicator	HzAV		Hz	Frequency unit
			A	Current unit
			V	Voltage unit
			RPM	Speed unit
			%	Percentage

5.2 Description of operation panel keys

Sign	Name	Function
	Parameter Setting/Esc Key	* Enter into the modified status of main menu * Esc from functional parameter modification * Esc submenu or functional menu to status menu
	Shift Key	* Choose displayed parameter circularly under running or stop interface; choose parameter's modified position when modify parameter
	Increasing Key	* Parameter or function number increasing, set by parameter F6.18
	Decreasing Key	* Parameter or function number decreasing, set by parameter F6.19
	Running Key	* For starting running in the mode of keyboard control status
	Stop/Reset Key	* For stopping running in the running status; for resetting the operation in the fault alarm status .the function of the key is subject to F6.00
	Enter Key	* Enter the menu screen step by step, set the parameter confirmation
	Quick Multifunction Key	*This key function is determined by the function code F6.21
	Keyboard Encoder	* F0.03 setting to 4, and the keyboard potentiometer setting the operating frequency

6.Standard specifications

Items		Specifications	
Power Input	Rated voltage	AC 1PH 220V(-15%)~240V(+10%) AC 3PH 220V(-15%)~240V(+10%) AC 3PH 380V(-15%)~440V(+10%) AC 3PH 480V±10%	
	Input AC voltage frequency	50Hz/60Hz	
	Allowing DC voltage fluctuations	G1/G2: DC 150~450V G3: DC 250~800V G4: DC 400~900V	
Control system	Control system	High performance vector control inverter based on DSP	
	Control method	V/F control, vector control W/O PG	
	Automatic torque boost function	Realize low frequency (1Hz) and large output torque control under the V/F control mode	
	Acceleration/deceleration control	Straight or S-curve mode. Four times available and time range is 0.0~6500.0s	
	V/F curve mode	Linear, square root/m-th power, custom V/F curve	
	Over load capability	G type: rated current 150% - 1 minute, rated current 180% - 2 seconds	
	Maximum frequency	1. Vector control:0~300Hz; 2.V/F control:0~3200Hz	
	Carrier Frequency	0.5~16kHz; automatically adjust carrier frequency according to the load characteristics	
	Input frequency resolution	Digital setting: 0.01Hz Analog setting: maximum frequency×0.025%	
	Start torque	G type: 0.5Hz/150% (vector control W/O PG)	
	Speed range	1:100 (vector control W/O PG)	
	Steady-speed precision	Vector control W/O PG: $\pm \leq 0.5\%$ (Rated synchronous speed)	
	Torque response	$\leq 20\text{ms}$ (vector control W/O PG)	
	Torque boost	Automatic torque boost; manual torque boost 0.1%~30.0%	
	Jogging control	Jog Frequency Range: 0.00Hz~max. frequency Jog Ac/deceleration time: 0.0s~6500.0s	
Built-in PID	Easy to realize closed-loop control system for the process control.		
Automatic voltage regulation(AVR)	Automatically maintain a constant output voltage when the voltage of electricity grid changes		
Special function of solar water pump	Maximum light power tracking, light intensity automatic sleep, light intensity automatic wake up, high water level automatic shutdown, low water level automatic operation, under-load protection etc		
Personalization function	Self-inspection of peripherals after power-on	After powering on, peripheral equipment will perform safety testing, such as ground, short circuit etc	
	Quick current limiting	The current limiting algorithm is used to reduce the inverter over current probability, and improve whole unit anti-interference capability.	
	Timing control	Timing control function: time setting range max 6500m	
Running	Input signal	DI input terminal	6 digital input terminals, DI5 can do high-speed pulse input (0 ~ 100kHz square wave);
		A11/A12 analog input	2 analog input terminals respectively for optional range (0~20mA or 0~10V), they can be used to set frequency, output frequency
		Start signal	Rotate forward/reverse
		Multi-speed	At most 16-speed can be set(Run by using the multi-function terminals or program)
		Emergency stop	Interrupt controller output
		Fault reset	When the protection function is active, you can automatically or manually reset the fault condition.
	Output Signal	PID feedback signal	Including DC 0~10V, DC 0~20mA
		Output terminal	1 channel collector output terminal SPA;1 circuit relay output terminal;1 channel DA1 analog output terminal
		SPA/ Relay output	Each channel has 40 signals to choose from .Contact capacity of relay: Normally open contact 5A/AC 250V;1 A/DC 30 V
		DA1 Analog output	One-way analog output, 16 signals can be selected such as frequency, current, voltage and others, output signal range0~10V/0~20mA
Running command channel	Three channels: Operation panel, control terminals and serial communication port. They can be switched through a variety of ways.		
Frequency source	Total 8 frequency sources: digital, analog voltage , multi-speed and serial port. They can be switched through a variety of ways.		
Running function	Limited frequency, avoidance frequency, slip compensation, self-tuning,		

Protection function	PID control.	
	Inverter protection Overvoltage protection, under-voltage protection, over-current protection, overload protection, overheat protection, over-current stall protection, overvoltage stall protection, losing-phase protection (optional), communication error, PID feedback signal abnormalities, PG failure and short circuit to ground protection.	
Display	LED display keyboard	Running information Monitoring objects including: Running frequency, set frequency, bus voltage, output voltage, output current, output power, output torque, input terminal status, output terminal status, analog AI1 value, analog AI2 value, motor actual running speed, PID set value percentage, PID feedback value percentage.
		Error message At most save three error message, and the fault type, voltage, current, frequency and work status can be queried when the failure is occurred.
	Key lock and function selection Lock part or all of keys, define the function scope of some keys to prevent misuse.	
	IGBT temperature Display current IGBT temperature inside inverter	
Communication	RS485 Built-in RS485 communication	
Environment Product standard	Environment temperature	-10℃~40℃ (temperature at 40℃~50℃, please derating to use)
	Storage temperature	-20℃~65℃
	Environment humidity	Less than 90% R.H, no condensation.
	Vibration	Below 5.9m/s ² (= 0.6g)
	Application sites	Indoor where no sunlight or corrosive, explosive gas and water vapor, dust, flammable gas, oil mist, water vapor, drip or salt, etc.
	Altitude	There is no reduction for use below 1000m, 1% reduction for every 100m rise above 1000m, and the maximum use altitude is 3000m
	Protection level	IP20
Product standard	Product adopts safety standards.	IEC61800-5-1
	Product adopts EMC standards.	IEC61800-3
Cooling method	Forced air cooling	

7. Wiring diagram

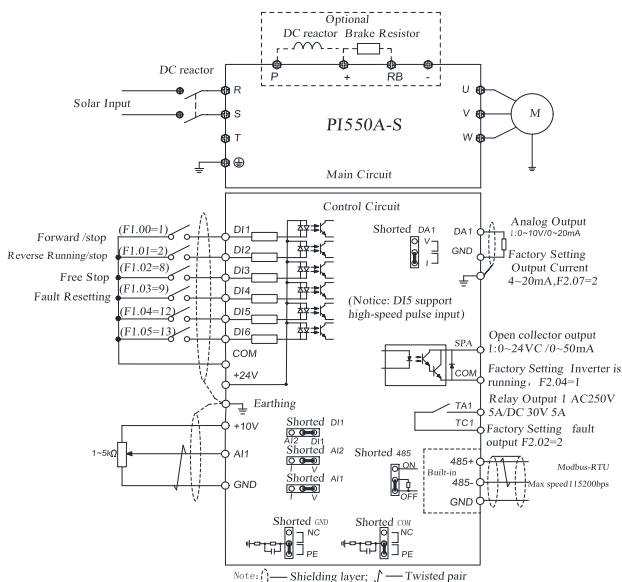

Main circuit wiring attentions

- (1)Wiring specifications, please implement wiring in accordance with electrical regulations;
- (2)Do not connect alternating current to the output end of the inverter (U, V, W), otherwise the inverter will be damaged;
- (3)Power supply wiring, please try to use the isolation wire and the wire tube, and the isolation wire or the two ends of the wire tube grounding;
- (4)The ground wire of the inverter shall not be grounded together with the welding machine, high-power motor or high-current load, and shall be grounded separately;
- (5)The earthing terminal Please correct \oplus grounding, grounding resistance less than 10 Ω ;

Control loop wiring attentions

- (1)Please separate the control signal line from the main circuit line, other power line and power line.
- (2)In order to prevent interference and cause wrong action, please use stranded shielding wire or double shielding wire, the specification is 0.5~2mm squared
- (3)Please determine the allowable conditions of each terminal, such as: Power supply, maximum allowable current, etc.;
- (4)Wiring requirements of all terminals, select accessories correctly, such as voltmeter, input power supply, etc.;
- (5)Please check the wiring correctly after completion, and power on after confirmation.

8. Brief table of parameters

In PI550A-S series inverters, some parameters are "reserved by the manufacturer", and their serial Numbers are not listed in the function parameter table, which results in the disconnection of some parameter serial Numbers in the table. For the parameters not introduced in the manual, please do not try to modify them to avoid causing errors.

d0 group Monitor function parameter groups

Code	Parameter name	Setting range	Company
d0.00	Running frequency	Actual output frequency	0.01Hz
d0.01	Set frequency	Actual set frequency	0.01Hz
d0.02	DC bus voltage	Detected value for DC bus voltage	0.1V
d0.03	output voltage	Actual output voltage	1V
d0.04	output current	Effective value for Actual motor current	0.01A
d0.05	output power	Calculated value for motor output power	0.1kW
d0.07	DI input status	DI input status	-
d0.08	DO output status	DO output status	-
d0.09	AI1 voltage (V)	AI1 input voltage value	0.01V
d0.10	AI2 voltage (V)	AI2 input voltage value	0.01V
d0.14	Actual operating speed	Motor actual running speed	-
d0.15	PID setting	Reference value percentage when PID runs	%
d0.16	PID feedback	Feedback value percentage when PID runs	%
d0.18	HDI(DI5) pulse frequency	HDI(DI5) High-speed pulse input frequency display, unit: 0.01Khz	0.01kHz
d0.19	Feedback speed	Inverter actual output frequency	0.01Hz
d0.20	Remaining run time	Remaining run time display, it is for timing run control	0.1Min
d0.22	Current power-on time	Total time of current inverter power-on	1Min
d0.23	Current run time	Total time of current inverter run	0.1Min
d0.24	HDI(DI5) pulse frequency	HDI(DI5) High-speed pulse input frequency display, unit: 1Hz	1Hz
d0.25	Communication set value	Frequency, torque or other command values set by communication port	0.01%
d0.27	Master frequency display	Frequency set by F0.03 master frequency setting source	0.01Hz
d0.36	Inverter type	1.G type (Constant torque load type) 2.F type (fans/pumps load type)	-
d0.37	AI1 voltage before correction	Input voltage value before AI1 linear correction	0.01V
d0.38	AI2 voltage before correction	Input voltage value before AI2 linear correction	0.01V

F0 group Basic function parameter group

Code	Parameter name	Setting range	Factory setting	Change
F0.00	Motor control manner	0.Vector control W/O PG; 1.Vector control W/ PG; 2.V/F control	2	★
F0.01	Keyboard set frequency	0.00Hz~F0.19 (Maximum frequency)	50.00Hz	☆
F0.02	Frequency command resolution	1: 0.1Hz; 2: 0.01Hz	2	★
F0.03	Frequency source master setting	0: keyboard setting frequency (F0.01, UP/DOWN can be modified, power loss is not memory) 1: keyboard setting frequency (F0.01, UP/DOWN can be modified, power off memory) 2: Setting of analog quantity AI1; 3: Setting of analog quantity AI2; 4: panel potentiometer setting 5: High-speed pulse setting; 6: multi-stage speed setting 7: Simple PLC program setting; 8: photovoltaic mode /PID control setting; 9: remote communication Settings	8	★
F0.11	Command source selection	0.Keyboard control (LED off) 1.Terminal block control (LED on) 2.Communications command control (LED flashes) 3. Keyboard control+ Communications command control 4. Keyboard control+ Communications command control+ Terminal block control	4	☆
F0.13	Acceleration time 1	0.00s~6500s	Depends on models	☆
F0.14	Deceleration time 1	0.00s~6500s	Depends on models	☆
F0.17	Carrier frequency adjustment as per temperature	0: NO; 1: YES	0	☆
F0.18	Carrier Frequency	0.5kHz~16.0kHz	Depends on models	☆
F0.19	Maximum output frequency	50.00Hz~320.00Hz	50.00Hz	★
F0.20	Upper limit frequency source	0: F0.21 setting; 1: AI1analog quantity setting 2: AI2analog quantity setting 3: Panel potentiometer setting; 4: High-speed pulse setting 5: Communications reference	0	★
F0.21	Upper limit frequency	F0.23 (Lower limit frequency)~F0.19 (Maximum frequency)	50.00Hz	☆
F0.22	Upper limit frequency offset	0.00Hz~F0.19 (Maximum frequency)	0.00Hz	☆
F0.23	Lower limit frequency	0.00Hz~F0.21 (Upper limit frequency)	0.00Hz	☆
F0.24	Running direction	0:Same direction; 1: Opposite direction	0	☆
F0.26	AI simulation quantity accuracy	0: 0.01Hz; 2: 0.1Hz; 1: 0.05Hz; 3: 0.5Hz	1	☆

Down-conversion curve can make the inverter output frequency quickly decline, to avoid power shortage lead to undervoltage. curve 4 is the fastest down, and curve 1 is the slowest. after modify the parameters, power-on again then it effective.

F1 group Input terminals group Change

Code	Parameter name	Setting range	Factory setting	Change
F1.00	DI1 terminal function selection	0~51	1	★
F1.01	DI2 terminal function selection		2	★
F1.02	DI3 terminal function selection		8	★
F1.03	DI4 terminal function selection		9	★
F1.04	DI5 terminal function selection		12	★
F1.05	DI6 terminal function selection		13	★

The functions of digital multi-function input terminals DI1-DI6 (where DI5 can be used as high-speed pulse input terminals) can be set by parameters F1.00-F1.05. The optional functions are shown in the table below.

Setting value	Function	Description
0	No function	The terminal for not use can be set to "no function" to prevent accidental operation.
1	Forward run (FWD)	External terminals are used to control the FWD/REV run mode of inverter
2	Reverse run (REV)	
3	Three-wire operation control	This terminal is used to determine the inverter's three-wire control mode. For details, please refer to the instructions of function code F1.10 ("terminal command mode").
4	Forward JOG(FJOG)	FJOG means Forward JOG running, RJOG means,reverse JOG running. For Jog running frequency and Jog Ac/deceleration time, please refer to the description of the function code F7.00, F7.01, F7.02.
5	Reverse JOG(RJOG)	
6	Terminal UP	Modify frequency increment/decrement command when the frequency is referenced by external terminal. Adjust up/down the set frequency when the digital setting is selected as the frequency source.
7	Terminal DOWN	
8	Free stop	The inverter output is blocked, at the time, the parking process of motor is not controlled by the inverter. This way is same as the principle of free stop described in F3.07.
9	Fault reset (RESET)	The function makes use of terminal for fault reset. It has same function with RESET key on the keyboard. This function can be used to realize remote fault reset.
10	Run pause	The inverter slows down and stops, but all operating parameters are memorized. Such as PLC parameters, PID parameters. This terminal signal disappears, the inverter reverts to the previous state of running before parking.
11	External fault normally open input	When the signal is sent to the inverter, inverter trips fault Err.15, and performs troubleshooting according to fault protection action (details refer to function code F8.17)

Option 12 ~ 51 omitted, If more choices needed, please contact us.

F1.10	Terminal command mode	Two-wire type 1; Three-wire type 1;	Two-wire type 2 Three-wire type 2	0	★
F1.11	Terminal UP/DOWN change rate	0.001Hz/s~65.535Hz/s		1.000Hz/s	☆
F1.12	AIC1 Minimum input	0.00V~F1.14		0.30V	☆
F1.13	F1.12corresponding setting	-100.0%~+100.0%		0.0%	☆
F1.14	AIC1 Maximum input	F1.12~+10.00V		10.00V	☆
F1.15	F1.14 corresponding setting	-100.0%~+100.0%		100.0%	☆
F1.26	HDI Minimum input	0.00kHz~F1.28		0.00kHz	☆
F1.27	F1.26 corresponding setting	-100.0%~+100.0%		0.0%	☆
F1.28	HDI Maximum input	F1.26~100.00kHz		50.00kHz	☆
F1.29	F1.28 corresponding setting	-100.0%~+100.0%		100.0%	☆
F1.30	DI Filtering time	0.000s~1.000s		0.010s	☆
F1.31	A11Filtering time	0.00s~10.00s		0.10s	☆
F1.34	HDIFiltering time	0.00s~10.00s		0.00s	☆
F1.35	DI Terminal Mode Selection 1	Unit digit :Di1 Terminal active state set 0:High level active 1: Low level active Ten digit:Di2 Terminal active state set(0~1,same as the units digit) Hundreds digit:Di3 Terminal active state set(0~1,same as the units digit) Thousand digit:Di4 Terminal active state set(0~1,same as the units digit) Ten thousands digit:Di5 Terminal active state set(0~1,same as the units digit)		00001	★
F1.36	DI Terminal Mode selection 2	Unit digit:Di6 ; 0:High level active;1:Low level active		00000	★
F1.37	DI1 delay time	0.0s~3600.0s		0.0s	★
F1.38	DI2 delay time	0.0s~3600.0s		0.0s	★
F1.39	DI3 delay time	0.0s~3600.0s		0.0s	★
F1.40	Define the input terminal repeat	0:Unrepeatable;	1:Repeatable	0	★

F2 group Output terminers parameters group

Code	Parameter name	Setting range	Factory setting	Change
F2.02	Relay 1 output function selection (TA1.TB1.TC1)	0~40	2	☆
F2.04	SPA output function selection (Collector open circuit output terminals)		1	☆

Relay, SPA output terminals functions description as below:

Setting value	Function	Description
0	No output	No output action
1	Inverter running	Inverter is in running state, the output frequency (can be zero), the output ON signal.
2	Fault output (fault down)	When the drive fails and downtime, the output ON signal.

3	Frequency level detection FDT1 output	Please refer to the function code F7.23, F7.24's instructions.
4	Frequency arrival	Please refer to the description of function code F7.25.
5	Zero-speed running (no output when shutdown)	Inverter operation and the output frequency is 0, output ON signal. When the drive is shut down, the signal is OFF.
6	Motor overload pre-alarm	Before the motor overload protection, according to the overload pre-alarm threshold value judgment, more than the pre-alarm threshold value output ON signal. Motor overload parameter settings refer to the function code F8.02 ~ F8.04.
7	Inverter overload pre-alarm	Before the inverter overload occurs 10s, output ON signal. Setup counter arrive
11	PLC cycle is complete	After simple PLC completes one cycle, the output of a pulse width of 250ms signal.
12	Total running time arrival	Inverter total running time of more than F7.21 F6.07 set time, the output ON signal.
13	Limited in frequency	When the set frequency exceeds the upper limit frequency or lower frequency, and output frequency is beyond the upper limit frequency or lower limit frequency, output ON signal.
15	Ready to run	When the inverter main circuit and control circuit power supply has stabilized, and the drive does not detect any fault information, the drive is in an operational state, output ON signal.
17	Upper frequency arrival	When the operating frequency reaches the upper frequency, output ON signal.
18	The lower frequency arrival	When the operating frequency reaches the lower
19	Under voltage state output	When the inverter is in an undervoltage condition, output ON signal.
20	Communication setting	Refer to the communication protocol.
23	Zero-speed operation 2 (shutdown also output)	The inverter's output frequency is 0, output ON signal. The signal is also ON when shutdown.
24	Cumulative power-on time arrival	When the inverter's accumulated power on time (F6.08) over F7.20 the set time, the output ON signal.
25	Frequency level detection FDT2 output	Please refer to the function code F7.26, F7.27's instructions.
26	Frequency 1 reaches output	Please refer to the function code F7.28, F7.29's instructions.
27	Frequency 2 reaches output	Please refer to the function code F7.30, F7.31's instructions.
28	Current 1 reaches output	Please refer to the function code F7.36, F7.37's instructions.
29	Current 2 reaches output	Please refer to the function code F7.38, F7.39's instructions.
30	Timing reach output	When the timer function selection (F7.42) is valid, the drive time to reach this run after the set time runs out, output ON signal.
31	A11 input overrun	When the value of analog input A11 greater than F7.51 (A11 input protection limit) or less than F7.50 (A11 input protection under), output ON signal.
33	Reverse operation	Inverter in reverse run, output ON signal.
34	0 current state	Refer to the description of function code F7.32, F7.33.
35	Module temperature reaches	Inverter module heatsink temperature (F6.06) reach the set module temperature reaches value (F7.40), output signal ON.
36	Software current limit	Please refer to the function code F7.34, F7.35's instructions.
37	The lower frequency arrival (Stop and output)	When the operating frequency reaches the lower limit frequency, output ON signal. In shutdown state of the signal is also ON.
38	Alarm output	When the inverter failure, and the failure of the process to continue to run mode, the inverter alarm output.
40	Current running time of arrival	When the inverter starts running time is longer than the time set by F7.45, it outputs ON signal.

F2.07	DA1 output function selection	0~17	2	☆
-------	-------------------------------	------	---	---

Analog Output DA1 and DA2 output range is 0V ~ 10V, or 0mA ~ 20mA. Pulse output or analog output range, with the corresponding scaling function relationship in the following table:

Setting value	Function	Description
0	Running frequency	0~Max. output frequency
1	Set frequency	0~Max. output frequency
2	Output current	0~2 times the motor rated current
3	Output torque	0~2 times the motor rated torque
4	Output power	0~2 times rated power
5	Output voltage	0~1.2 times inverter rated voltage
6	High speed pulse input	0.01kHz~100.00kHz
7	Analog AI1	0~10V (/0~20mA)
8	Analog AI2	0~10V (/0~20mA)
12	Communication set	0.0%~100.0%
13	Motor speed	0~Max. output frequency correspondent speed
14	Output current	0.0A~100.0A(Inverter power ≤ 55kW); 0.0A~1000.0A(Inverter power > 55kW)
15	DC bus voltage	0.0~1000.0V
17	Frequency source main set	0~Max. output frequency

F2.11	Relay 1 output delay time	0.0s~3600.0s	0.0s	☆
F2.13	SPA output delay time	0.0s~3600.0s	0.0s	☆
F2.15	DO terminal active status selection	Unit digits: Reverse ; Tens digit: Relay 1 0: Positive Logic; 1: Negative Logic Hundreds digit: Reserve Thousands digit: SPA Tens thousand digit: Reserve	00000	☆
F2.16	DA1 Zero bias coefficient	-100.0%~+100.0%	20%	☆
F2.17	DA1 gain	-10.00~+10.00	0.80	☆

F3 group Start-stop control parameter group

Code	Parameter name	Setting range	Factory setting	Change
F3.00	Start-up mode	0:Direct startup; 2:Pre-excitation start (AC asynchronous motor)	0	☆
F3.03	Start frequency	0.00Hz~10.00Hz	0.00Hz	☆
F3.04	Hold time for start frequency	0.0s~100.0s	0.0s	★
F3.05	DC Pre-excitation current	0%~100%	0%	★
F3.06	DC Pre-excitation current	0.0s~100.0s	0.0s	★
F3.07	Stop mode	0:Deceleration stop; 1: Free stop	0	☆
F3.08	DC start frequency	0.00Hz~F0.19(Maximum frequency)	0.00Hz	☆

F3.09	DC waiting time	0.0s~100.0s	0.0s	☆
F3.10	Stop braking current	0%~100%	0%	☆
F3.11	Stop braking current	0.0s~100.0s	0.0s	☆

F4 group V/F control parameter group

Code	Parameter name	Setting range	Factory setting	Change
F4.00	V/F curve setting	0 Linear V/F 1 Multi-point V/F 2 Square V/F 3 1.2th power V/F 4 1.4th power V/F 6 1.6th power V/F 8 1.8th power V/F ; 10 V/F completely separate 11 V/F half separate	0	★
F4.01	Torque boost	0.0%: Automatic torque boost 0.1%~30.0%	0.0%	★
F4.02	Torque boost cut-off frequency	0.00Hz~F0.19 (Maximum frequency)	15.00Hz	★
F4.03	V/F Frequency point1	0.00Hz~F4.05	0.00Hz	★
F4.04	V/F voltage point1	0.0%~100.0%	0.0%	★
F4.05	V/F frequency point 2	F4.03~F4.07	0.00Hz	★
F4.06	V/F voltage point 2	0.0%~100.0%	0.0%	★
F4.07	V/F frequency point3	F4.05~b0.04(Motor rated frequency)	0.00Hz	★
F4.08	V/F voltage point 3	0.0%~100.0%	0.0%	★
F4.09	V/F slip compensation gain	0.0%~200.0%	0.0%	☆
F4.10	V/F overexcitation gain	0~200	80	☆
F4.11	V/F oscillation suppression gain	0~100	0	☆
F4.12	V/F Separated voltage source	0~9	0	☆
F4.13	Voltage Digital Setting	0V~motor rated voltage	0V	☆
F4.14	Voltage rise time	0.0s~1000.0s	0.0s	☆

F6 group Keyboard and Display

Code	Parameter name	Setting range	Factory setting	Change	
F6.00	STOP/RESET key functions	0:STOP/RESET key is enabled only under keyboard operation mode 1: STOP/RESET key is enabled under any operation mode	1	☆	
F6.01	Running status display parameters 1	0x0000~0xFFFF	001F	☆	
F6.03	Stop status display parameters	0x0001~0xFFFF	0033	☆	
F6.04	Load speed Display Coefficient	0.0001~6.5000	3.0000	☆	
F6.05	Load speed Display decimals	0:0 decimals ; 1:1 decimals ;	2:2 decimals 3:3 decimals	1	☆
F6.06	Inverter module radiator temperature	0.0℃~100.0℃	-	●	
F6.07	Total run time	0h~65535h	-	●	
F6.08	Total power-on time	0h~65535h	-	●	
F6.09	Total power consumption	0~65535kw.h	-	●	
F6.10	Part number	Inverter product number	-	●	
F6.11	Software version number	Control panel software version number	-	●	
F6.13	Dormancy function	0:Invalid; 1:valid	1	☆	
E0.03 (wake-up delay time), E0.09 (sleep frequency) and E0.11 (sleep delay time) functions only work when the sleep function setting (F6.13=1) is effective.					
F6.17	Power correction coefficient	0.00~10.00	1.00	☆	
F6.20	Keyboard lock selection	0: Only RUN and STOP keys are valid. 2: Only RUN, STOP, UP, DOWN keys are valid 3: Only STOP key is valid; Note: Keyboard potentiometer is not restricted by this function.	0	☆	
F6.21	QUICK key function selection	0: No function; 1: Click operation; 2: Shift key switching display state; 3: Forward and reverse switching; 4: Clear UP/DOWN settings; 5: Free shutdown; 6: Realize the switching of the given mode of	1	☆	

		running commands in order:		
--	--	----------------------------	--	--

F7 group Auxiliary Functional Parameters Group

Code	Parameter name	Setting range	Factory setting	Change
F7.00	Jog running frequency	0.00Hz~F0.19(Maximum frequency)	6.00Hz	☆
F7.01	Jog acceleration time	0.0s~6500.0s	5.0s	☆
F7.02	Jog deceleration time	0.0s~6500.0s	5.0s	☆
F7.03	Jog priority	0:Invalid 1: Valid	1	☆
F7.04	Jump frequency 1	0.00Hz~F0.19 (Maximum frequency)	0.00Hz	☆
F7.05	Jump frequency 2	0.00Hz~F0.19(Maximum frequency)	0.00Hz	☆
F7.06	Jump frequency range	0.00Hz~F0.19 (Maximum frequency)	0.00Hz	☆
F7.07	Jump frequency availability during ac/deceleration process	0: Invalid 1: Valid	0	☆
F7.08	Acceleration time 2	0.0s~6500.0s	Depends on models	☆
F7.09	Deceleration time 2	0.0s~6500.0s	Depends on models	☆
F7.10	Acceleration time 3	0.0s~6500.0s	Depends on models	☆
F7.11	Deceleration time 3	0.0s~6500.0s	Depends on models	☆
F7.12	Acceleration time 4	0.0s~6500.0s	Depends on models	☆
F7.13	Deceleration time 4	0.0s~6500.0s	Depends on models	☆
F7.14	Switching frequency point between acceleration time 1 and acceleration time 2	0.00Hz~F0.19 (Maximum frequency)	0.00Hz	☆
F7.15	Switching frequency point between deceleration time 1 and deceleration time 2	0.00Hz~F0.19 (Maximum frequency)	0.00Hz	☆
F7.16	Forward/reverse rotation deadband	0.00s~3600.0s	0.00s	☆
F7.17	Reverse rotation control	0: Enable 1: Disable	0	☆
F7.18	Set frequency lower than lower limit frequency mode	0: Running at lower limit frequency 1: Stop 2: zero speed running	0	☆
F7.19	Droop control	0.00Hz~10.00Hz	0.00Hz	☆
F7.20	Setting cumulative power-on arrival time	0h~36000h	0h	☆
F7.21	Setting cumulative running arrival time	0h~36000h	0h	☆
F7.22	Start protection selection	0: OFF 1: ON	0	☆
F7.23	Frequency detection value (FDT1)	0.00Hz~F0.19(Maximum frequency)	50.00Hz	☆
F7.24	Frequency detection hysteresis value (FDT1)	0.0%~100.0% (FDT1 level)	5.0%	☆
F7.25	Frequency reaches detection width	0.00~100% (Maximum frequency)	0.0%	☆
F7.26	Frequency detection value (FDT2)	0.00Hz~F0.19 (Maximum frequency)	50.00Hz	☆
F7.27	Frequency detection hysteresis value (FDT2)	0.0%~100.0% (FDT2 level)	5.0%	☆
F7.28	Random arrivals frequency detection value 1	0.00Hz~F0.19 (Maximum frequency)	50.00Hz	☆
F7.29	Random arrivals frequency detection width 1	0.00%~100.0% (Maximum frequency)	0.0%	☆
F7.30	Random arrivals frequency detection value 2	0.00Hz~F0.19 (Maximum frequency)	50.00Hz	☆
F7.31	Random arrivals frequency detection width 2	0.00%~100.0% (Maximum frequency)	0.0%	☆
F7.32	Zero current detection level	0.0%~300.0% (Rated motor current)	5.0%	☆
F7.33	Zero current detection delay time	0.01s~360.00s	0.10s	☆
F7.34	Overrun value of output current	0.0% (not detected) 0.1%~300.0% (Rated motor current)	200.0%	☆
F7.35	Output current overrun detection delay time	0.00s~360.00s	0.00s	☆
F7.36	Random arrivals current 1	0.0%~300.0% (Rated motor current)	-100.0%	☆
F7.37	Random arrivals current 1 width	0.0%~300.0% (Rated motor current)	0.0%	☆
F7.38	Random arrivals current 2	0.0%~300.0% (Rated motor current)	-100.0%	☆
F7.39	Random arrivals current 2 width	0.0%~300.0% (Rated motor current)	0.0%	☆
F7.40	Module temperature arrival	0℃~100℃	75℃	☆
F7.41	Cooling fan control	0: Fan running only when running 1: Fan always running	0	☆
F7.42	Timing function selection	0: Invalid 1: Valid	0	★
F7.43	Timing run time selection	0: F7.44 setting; 1: AI1; 2: AI2 3: Panel potentiometer Analog input range corresponds to F7.44	0	★
F7.44	Timing run time	0.0Min~6500.0Min	0.0Min	★
F7.45	Current running reaches the set time.	0.0Min~6500.0Min	0.0Min	★
F7.50	All input voltage protection lower limit	0.00V~F7.51	3.1V	☆

F7.51	All input voltage protection upper limit	F7.50~10.00V	6.8V	☆
-------	--	--------------	------	---

F8 group Group - Fault and protection

Code	Parameter name	Setting range	Factory setting	Change
F8.00	Overcurrent stall gain	0~100	20	☆
F8.01	Overcurrent stall protection current	100%~200%	-	☆
F8.02	Motor overload protection selection	0: Invalid 1: Enable	1	☆
F8.03	Motor overload protection gain	0.20~10.00	1.00	☆
F8.04	Motor overload pre-alarm coefficient	50%~100%	80%	☆
F8.05	Over-voltage stall gain	0~100	0	☆
F8.06	Over-voltage stall protection voltage / energy consumption brake voltage	120%~150%	130%	☆
F8.08	Output phase loss protection selection	0: Invalid 1: Enable	1	☆
F8.09	Short to ground protection	0:Invalid 1: Valid	1	☆
F8.10	Number of automatic fault reset	0~32767	0	☆
F8.11	Fault DO action selection during automatic fault reset	0: OFF 1: ON	0	☆
F8.12	Automatic fault reset interval	0.1s~100.0s	1.0s	☆
F8.25	Abnormal reserve frequency	60.0%~100.0%	100%	☆
F8.26	Momentary power cut action selection	0: Invalid 1: Deceleration 2: Deceleration and stop	0	☆
F8.28	Recovery voltage judgment time of momentary power cut	0.00s~100.00s	0.50s	☆
F8.29	Judgment voltage of momentary power cut action	50.0%~100.0%(Standard bus voltage)	80%	☆
F8.30	Load drop protection selection	0: Invalid 1: Valid	0	☆
F8.31	load drop detection level	0.0~100.0%(Rated motor current)	10.0%	☆
F8.32	Load drop detection time	0.0~60.0s	1.0s	☆
F8.36	Low light enable	0: Invalid 1: Valid	0	☆
F8.37	Low light state retention time	0~6500.0s	20s	☆
F8.38	Low light recording frequency adjustment	-10.00~10.00Hz	-1.00Hz	☆
F8.39	Low light level	2~10	7	☆

If the download protection function is effective, when the output current of the inverter is less than the download detection level F8.31 and the duration is longer than the download detection time F8.32, the inverter reduces the downtime and starts operation after the E0.10 download check interval. If the load is restored during the deceleration process of download protection, the frequency inverter will automatically restore to run at the set frequency.

F9 group Group - Communication parameter

Code	Parameter name	Setting range	Factory setting	Change
F9.00	Baud rate	Units digit:MODBUS Tens digit:Profibus-DP Hundreds digit:Reserve Thousands digit:CAN bus baudrate	6005	☆
F9.01	Data format	0: No parity (8-N-2) 2: Odd parity (8-O-1) 1: Even parity (8-E-1); 3: No parity (8-N-1)	0	☆
F9.02	This unit address	1-250, 0 for broadcast address	1	☆
F9.03	Response delay	0ms-20ms	2ms	☆
F9.04	Communication timeout time	0.0 (Invalid) ; 0.1~60.0s	0.0	☆
F9.05	Data protocol selection	Units digit: MODBUS 0: Non-standard MODBUS protocol 1: Standard MODBUS protocol Tens digit: Profibus-DP 0: PP01 format 1: PP02 format 2: PP03 format 3: PP05 format	31	☆
F9.06	Current resolution	0: 0.01A 1: 0.1A	0	☆
F9.07	Baud rate	0 MODBUS	0	☆
F9.08	Undefined			

Fb group Control optimization parameters

Code	Parameter name	Setting range	Factory setting	Change
Fb.00	Fast current limiting manner	0: Invalid 1: Enable	1	☆
Fb.01	Under-voltage point setting	1.0%~200.0%	1.0%	☆
Fb.02	Over-voltage point setting	200.0~2500.0V	-	★
Fb.03	Deadband compensation mode selection	0: No compensation 1: Compensation mode 1 2: Compensation mode 2	1	☆
Fb.04	Current detection compensation	0~100	5	☆
Fb.05	Vector optimization without PG mode selection	0: No optimization 1: Optimization mode 1 2: Optimization mode 2	1	★
Fb.06	Upper limiting frequency for DPWM switching	0.00~15.00Hz	12.00Hz	☆
Fb.07	PWM modulation manner	0:Asynchronous;1:Synchronous	0	☆
Fb.08	Random PWM depth	0: Invalid 1~10: PWM carrier frequency random depth	0	☆

E0 group Wobulate, fixed-length and counting

Code	Parameter name	Setting range	Factory setting	Change
E0.00	Solar operation mode selection	0: Control mode invalid; 1:CVT Mode; 2: MPPT Mode	2	☆
<p>0: PV invalid Photovoltaic effect does not work; when normal operation model, need to set E0.00=0. 1: CVT mode Bus voltage is constant as a given value, F0.03 is set to 8, photovoltaic mode, bus voltage is given as E0.01, feedback the current bus voltage. 2: MPPT mode Bus voltage is given as the maximum power search result, F0.03 is set to 8, photovoltaic mode. When starting but before the searching, the bus voltage is given as E0.01, at intervals after the search, the search result is as given value.</p>				
E0.01	Solar voltage setting	Solar voltage setting	Confirmed model type	☆
<p>When set E0.00 to 1, this voltage is CVT mode bus voltage set value; When set E0.00 to 2, the voltage is the bus voltage given value when MPPT mode be started, and also the initial value when search voltage. Appropriate adjustments according to the site conditions. Note: the set value should be lower than the bus voltage value, if the value is higher than the bus voltage, the inverter may run at around 0Hz during start. 220V voltage level corresponding to bus DC310V; 380V voltage level corresponding to bus DC540V; 480V voltage level corresponding to bus DC620V.</p>				
E0.02	MPPT Voltage search interval time	0.0~1000.0s	2.0s	☆
<p>MPPT Interval search time when set E0.00 to 2. It indicates the speed of MPPT tracking, lower numbers equate to better speed on MPPT tracking, but the MPPT searching interval is short, may result in more fluctuations on output frequency of the inverter</p>				
E0.03	Wake up delay time	0~10000s	300s	☆
<p>When using the sleep function, set F6.13 = 1 (valid). During the operation of the inverter, when the running frequency is less than E0.09 sleep frequency, after the E0.11 sleep delay time, the inverter enters the sleep state and decelerates to stop. If the frequency inverter dormant, run command valid, after E0.03 awakens the delay time, frequency inverter to start.</p>				
E0.04	Upper limit of MPPT search voltage	0.0~1000.0V	Confirmed model type	☆
<p>Search value of upper limit voltage in MPPT search process. 220V voltage level search upper limit is DC400V; 380V voltage level search upper limit is DC650V; 480V voltage level search upper limit is DC730V.</p>				
E0.05	Lower limit of MPPT search voltage	0.00~1000.0V	Confirmed model type	☆
<p>Search value of lower limit voltage in MPPT search process. 220V voltage level search lower limit is DC270V; 380V voltage level search lower limit is DC480V; 480V voltage level search lower limit is DC560V.</p>				
E0.06	PID maximum voltage deviation value	0.0~1000.0V	10.0V	☆
<p>When Photovoltaic mode works, by changing parameters, can limit given bus voltage and current bus voltage's PID maximum input voltage deviation value</p>				
E0.07	Solar wake voltage	0.0~1000.0V	Confirmed model type	☆
<p>When inverter is into hibernation, if the bus voltage gradually higher than the set voltage(E0.07), the inverter will start automatically. 220V voltage level wake voltage is DC300V; 380V voltage level wake voltage is DC530V; 480V voltage level wake voltage is DC610V.</p>				
E0.08	Solar hibernation voltage	0.0~1000.0V	Confirmed model type	☆
<p>When inverter is running, when the bus voltage is lower than the set voltage (E0.08), inverter will go into hibernation. 220V voltage level hibernation voltage is DC200V; 380V voltage level hibernation voltage is DC430V; 480V voltage level hibernation voltage is DC480V.</p>				
E0.09	Hibernation frequency	0~Max frequency(F0.19)	30.00Hz	☆
<p>Hibernation frequency (E0.09) Used with wake-up delay time (E0.03) and hibernation delay time (E0.11), check E0.03 for functional description.</p>				
E0.10	Load drop detection interval time	0~65535s	6000s	☆
<p>When using the load detection interval, set F8.30 ~ F8.32. After the inverter falls off, Restart the operation after the time which set by E 0.10.</p>				
E0.11	Hibernation delay time	0~10000s	100	☆
<p>Hibernation delay time(E0.11)Used with wake-up delay time (E0.03) and hibernation frequency (E0.09), check E0.03 for functional description.</p>				

E1 group Multi-speed, Simple PLC Group

Code	Parameter name	Setting range	Factory setting	Change
E1.00 ~E1.15	0-stage speed setting 0X ~ 15-stage speed setting 15X	-100.0%~100.0%	0.0%	☆
E1.16	Simple PLC running mode	0: Stop after single running 1: Hold final value after single running 2: Circulating	0	☆
E1.17	Simple PLC power-down memory selection	Units digit: Power-down memory Selection: 0: Power-down without memory; 1: Power-down with memory. Tens digit: Stop memory selection: 0: Stop without memory; 1: Stop with memory.	11	☆
E1.18	0 stage running time T0	0.0s(h)~6500.0s(h)	0.0s(h)	☆
E1.19	0 stage ac/deceleration time selection	0:F0.13,F0.14; 1:F7.08,F7.09; 2:F7.10,F7.11; 3:F7.12,F7.13	0	☆
E1.20	1 stage running time T1	0.0s(h)~6500.0s(h)	0.0s(h)	☆
E1.21	1 stage ac/deceleration time selection	Same as E1.19	0	☆
E1.22	2 stage running time T2	0.0s(h)~6500.0s(h)	0.0s(h)	☆
E1.23	2 stage ac/deceleration time selection	Same as E1.19	0	☆
E1.24	3 stage running time T3	0.0s(h)~6500.0s(h)	0.0s(h)	☆

E1.25	3 stage ac/deceleration time selection	Same as E1.19	0	☆
E1.26	4 stage running time T4	0.0s(h)~6500.0s(h)	0.0s(h)	☆
E1.27	4 stage ac/deceleration time selection	Same as E1.19	0	☆
E1.28	5 stage running time T5	0.0s(h)~6500.0s(h)	0.0s(h)	☆
E1.29	5 stage ac/deceleration time selection	Same as E1.19	0	☆
E1.30	6 stage running time T6	0.0s(h)~6500.0s(h)	0.0s(h)	☆
E1.31	6 stage ac/deceleration time selection	Same as E1.19	0	☆
E1.32	7 stage running time T7	0.0s(h)~6500.0s(h)	0.0s(h)	☆
E1.33	7 stage ac/deceleration time selection	Same as E1.19	0	☆
E1.34	8 stage running time T8	0.0s(h)~6500.0s(h)	0.0s(h)	☆
E1.35	8 stage ac/deceleration time selection	Same as E1.19	0	☆
E1.36	9 stage running time T9	0.0s(h)~6500.0s(h)	0.0s(h)	☆
E1.37	9 stage ac/deceleration time selection	Same as E1.19	0	☆
E1.38	10 stage running time T10	0.0s(h)~6500.0s(h)	0.0s(h)	☆
E1.39	10 stage ac/deceleration time selection	Same as E1.19	0	☆
E1.40	11 stage running time T11	0.0s(h)~6500.0s(h)	0.0s(h)	☆
E1.41	11 stage ac/deceleration time selection	Same as E1.19	0	☆
E1.42	12 stage running time T12	0.0s(h)~6500.0s(h)	0.0s(h)	☆
E1.43	12 stage ac/deceleration time selection	Same as E1.19	0	☆
E1.44	13 stage running time T13	0.0s(h)~6500.0s(h)	0.0s(h)	☆
E1.45	13 stage ac/deceleration time selection	Same as E1.19	0	☆
E1.46	14 stage running time T14	0.0s(h)~6500.0s(h)	0.0s(h)	☆
E1.47	14 stage ac/deceleration time selection	Same as E1.19	0	☆
E1.48	15 stage running time T15	0.0s(h)~6500.0s(h)	0.0s(h)	☆
E1.49	15 stage ac/deceleration time selection	Same as E1.19	0	☆
E1.50	Simple PLC run-time unit	0:s(second); 1:h(hour)	0	☆
E1.51	Multi-stage command 0 reference manner	0: Function code E1.00 reference 1: Analog AI1 reference 2: Analog AI2 reference 3: Panel potentiometer setting 4: High-speed pulse setting 5: PID control setting 6:Keyboard set frequency (F0.01) Setting, UP/DOWN modifiable	0	☆

E2 group PID function Group

Code	Parameter name	Setting range	Factory setting	Change
E2.00	PID setting source	0: E2.01 setting 1: Analog AI1 reference 2: Analog AI2 reference 3: Panel potentiometer setting 4: High-speed pulse setting 5: Communications reference 6: Multi-stage command reference	0	☆
E2.01	PID keyboard reference	0.0%~100.0%	50.0%	☆
E2.02	PID feedback source	0: Analog AI1 reference 1: Analog AI2 reference 2: Panel potentiometer setting 4: High-speed pulse setting 5: Communications reference 6: AI1+AI2 reference 7: MAX(AI1 , AI2) reference 8: MIN(AI1 , AI2) reference	0	☆
E2.03	PID action direction	0:Positive; 1:Negative	0	☆
E2.04	PID setting feedback range	0~65535	1000	☆
E2.05	PID inversion cutoff frequency	0.00~F0.19(Maximum frequency)	0.00Hz	☆
E2.06	PID deviation limit	0.0%~100.0%	2.0%	☆
E2.07	PID differential limiting	0.00%~100.00%	0.10%	☆
E2.08	PID reference change time	0.00s~650.00s	0.00s	☆
E2.09	PID feedback filter time	0.00s~60.00s	0.00s	☆
E2.10	PID output filter time	0.00s~60.00s	0.00s	☆
E2.11	PID feedback loss detection value	0.0%:Not judged feedback loss; 0.1%~100.0%	0.0%	☆
E2.12	PID feedback loss detection time	0.0s~20.0s	0.0s	☆
E2.13	Proportional gain KP1	0.0~200.0	80.0	☆
E2.14	Integration time Ti1	0.01s~10.00s	0.50s	☆
E2.15	Differential time Td1	0.000s~10.000s	0.000s	☆
E2.16	Proportional gain KP2	0.0~200.0	20.0	☆
E2.17	Integration time Ti2	0.01~10.00s	2.00s	☆
E2.18	Differential time Td2	0.00~10.000s	0.000s	☆
E2.19	PID parameter switching conditions	0:No switching; 1:Switching via terminals 2:Automatically switching according to deviation	0	☆
E2.20	PID parameter switching deviation 1	0.0%~E2.21	20.0%	☆
E2.21	PID parameter switching deviation 2	E2.20~100.0%	80.0%	☆

E2.22	PID integral properties	Units digit: integral separation 0: Invalid 1: Valid Tens digit: whether stop integration when output reaches limit 0:Continue 1:Stop	00	☆
E2.23	PID initial value	0.0%~100.0%	0.0%	☆
E2.24	PID initial value hold time	0.00s~360.00s	0.00s	☆

b0 group Motor parameters Group

Code	Parameter name	Setting range	Factory setting	Change
b0.00	Motor type selection	0:General asynchronous motor; 1: Asynchronous inverter motor	0	★
b0.01	Rated power	0.1~1000.0kW	Confirmed model type	★
b0.02	Rated voltage	1~2000V	Confirmed model type	★
b0.03	Rated current	0.01A~655.35A(Inverter power≤55kW) 0.1A~6553.5A((Inverter rate>55kW)	Confirmed model type	★
b0.04	Rated frequency	0.01Hz~F0.19(Maximum frequency)	Confirmed model type	★
b0.05	Rated speed	1rpm~36000rpm	Confirmed model type	★
b0.06	Asynchronous motor stator resistance	0.001Ω~65.535Ω(Inverter power ≤55kW) 0.0001Ω~6.5535Ω(Inverter power >55kW)	Motor parameters	★
b0.07	Asynchronous motor rotor resistance	0.001Ω~65.535Ω(Inverter power ≤55kW) 0.0001Ω~6.5535Ω(Inverter power >55kW)	Motor parameters	★
b0.08	Asynchronous motor leakage inductance	0.01mH~655.35mH(Inverter power ≤55kW) 0.001mH~65.535mH(Inverter power >55kW)	Motor parameters	★
b0.09	Asynchronous motor mutual inductance	0.1mH~6553.5mH(Inverter power ≤55kW) 0.01mH~655.35mH(Inverter power >55kW)	Motor parameters	★
b0.10	Asynchronous motor no-load current	0.01A~b0.03(Inverter power ≤55kW) 0.1A~b0.03(Inverter power >55kW)	Motor parameters	★
b0.27	Motor parameter auto tuning	0:No operation 1:Asynchronous motor parameters still auto tuning 2:Asynchronous motor parameters comprehensive auto tuning	0	★

y0 group Function code management group

Code	Parameter name	Setting range	Factory setting	Change
y0.00	Parameter initialization	0:No operation 1:Restore default parameter values, not including motor parameters 2:Clear history 3:Restore default parameter values, including motor parameters 4:Backup current user parameters 501:Restore from backup user parameters	0	★
y0.01	User password	0~65535	0	☆
y0.02	Function parameter group display selection	Units digit: d group display selection 0:No displays; 1:Displays Tens digit: E group display selection(The same above) Hundreds digit: b group display selection(The same above) Thousands digit: y group display selection(The same above) Tens thousands digit: L group display selection(The same above)	11111	★
y0.03	Personality parameter group display selection	Units digit:Reserved Tens digit :User's change parameter display selection 0:Nodisplay 1:Display	00	☆
y0.04	Function code modification properties	0:Modifiable; 1:Not modifiable	0	☆
y0.05	Undefined			

y1 group Fault query parameter group

Code	Parameter name	Setting range	Factory setting	Change
y1.00	Type of the first fault	0:Fault-free; 1: Inverter unit protection;	-	●
y1.01	Type of the second fault	2: Accelerated overcurrent; 3: Deceleration overcurrent; 4: Constant speed overcurrent; 5: Accelerating overvoltage; 6: Decelerating overvoltage; 7:Constant speed overvoltage; 8: Control power failure; 9: Undervoltage; 10:Inverter overload; 11:Motor overload;	-	●
y1.02	Type of the third(at last) fault	13: Output phase missing 14: Module overheating; 15: External fault; 16: Abnormal communication; 17: Abnormal contactor; 18: Abnormal current detection; 19: Abnormal motor self-learning; 21: Parametric read-write abnormality; 22: Inverter hardware abnormality; 23:Short circuit between motor and ground; 26:Running	-	●

		time arrives; 27: User-defined Fault 1; 28: User-defined fault 2; 29: Power-on time arrives; 31:The PID feedback is lost during operation. 40:Fast current limiting timeout; 51:Initial position error; COF: Communication failure		
y1.03	Frequency of the third(at last) fault	-	-	●
y1.04	Current of the third(at last) fault	-	-	●
y1.05	Bus voltage of the third(at last) fault	-	-	●
y1.06	Input terminal status of the third(at last) fault	-	-	●
y1.07	Output terminal status of the third(at last) fault	-	-	●
y1.09	Power-on time of the third(at last) fault	-	-	●
y1.10	Running time of the third(at last) fault	-	-	●
y1.13	Frequency of the second fault	-	-	●
y1.14	Current of the second fault	-	-	●
y1.15	Bus voltage of the second fault	-	-	●
y1.16	Input terminal status of the second fault	-	-	●
y1.17	Output terminal status of the second fault	-	-	●
y1.19	Power-on time of the second fault	-	-	●
y1.20	Running time of the second fault	-	-	●
y1.23	Frequency of the first fault	-	-	●
y1.24	Current of the first fault	-	-	●
y1.25	Bus voltage of the first fault	-	-	●
y1.26	Input terminal status of the first fault	-	-	●
y1.27	Output terminal status of the first fault	-	-	●
y1.29	Power-on time of the first fault	-	-	●
y1.30	Running time of the first fault	-	-	●

9.Fault alarm and countermeasures

PI550A-S can provide effective protection when the equipment performance is played fully. In case of abnormal fault, the protection function will be invoked, the inverter will stop output, and the fault code will be displayed on the display panel of the inverter. Before consulting the service department, user can perform self-check , analyze the fault cause and find out the solution according to the instructions of this chapter. If the fault is caused by the reasons as described in the dotted frame, please consult the agents of inverter or directly contact with our company.

No.	Fault ID	Failure type	Possible causes	Solutions
1	Err.01	Inverter unit protection	1.The short circuit of inverter output happens 2.The wiring for the motor and the inverter is too long 3.module overheating 4.The internal wiring of inverter is loose 5.The main control panel is abnormal 6.The drive panel is abnormal. 7.The inverter module is abnormal	1.Eliminate peripheral faults 2.Additionally install the reactor or the output filter 3.Check the air duct is blocked or not and the fan is working normally or not, and eliminate problems 4.Correctly plug all cables 5.Seek for technical support
2	Err.02	Acceleration overcurrent	1.The acceleration time is too short 2.manual torque boost or V/F curve is not suitable 3.The voltage is low 4.The short-circuit or earthing of inverter output happens 5.The control mode is vector and without identification of parameters 6.The motor that is rotating is started unexpectedly. 7.Suddenly increase the load in the process of acceleration. 8.The type selection of inverter is small	1.Increase acceleration time 2.Adjust manual torque boost or V/F curve 3.Set the voltage to the normal range 4.Eliminate peripheral faults 5.Perform identification for the motor parameters 6.Select Speed Tracking Start or restart after stopping the motor. 7.Cancel the sudden load 8.Choose the inverter with large power level
3	Err.03	Deceleration overcurrent	1.The short-circuit or earthing of inverter output happens 2.The control mode is vector and without identification of parameters 3.The deceleration time is too short 4.The voltage is low 5.Suddenly increase the load in the process of deceleration. 6.Didn't install braking unit and braking resistor	1.Eliminate peripheral faults 2.Perform identification for the motor parameters 3.Increase the deceleration time 4.Set the voltage to the normal range 5.Cancel the sudden load 6.Install braking unit and brake resistor
4	Err.04	Constant speed overcurrent	1.The short-circuit or earthing of inverter output happens 2.The control mode is vector and without identification of parameters 3.The voltage is low 4, whether suddenly increase the load when running 5.The type selection of inverter is small	1.Eliminate peripheral faults 2.Perform identification for the motor parameters 3.Set the voltage to the normal range 4.Cancel the sudden load 5.Choose the inverter with large power level
5	Err.05	Acceleration overvoltage	1.Didn't install braking unit and braking resistor 2.The input voltage is high 3.There is external force to drag the motor to run when accelerating. 4.The acceleration time is too short	1.Install braking unit and brake resistor 2.Set the voltage to the normal range 3.Cancel the external force or install braking resistor. 4.Increase acceleration time
6	Err.06	Deceleration overvoltage	1.The input voltage is high 2.There is external force to drag the motor to run when decelerating.	1.Set the voltage to the normal range 2.Cancel the external force or

No.	Fault ID	Failure type	Possible causes	Solutions
			3.The deceleration time is too short 4.Didn't install braking unit and braking resistor	install braking resistor. 3.Increase the deceleration time 4.Install braking unit and brake resistor
7	Err.07	Constant speed overvoltage	1.There is external force to drag the motor to run when running 2.The input voltage is high	1.Cancel the external force or install braking resistor. 2.Set the voltage to the normal range
8	Err.08	Control power failure	1.The range of input voltage is not within the specification 2.frequent under-voltage fault	Adjust the voltage to the range of the requirements of specification
9	Err.09	Under voltage fault	1.The momentary power cut 2.The inverter's input voltage is not within the specification 3.The bus voltage is not normal 4.The rectifier bridge and buffer resistance are abnormal 5.The drive panel is abnormal. 6.The control panel is abnormal	1.Reset fault 2.Adjust the voltage to the normal range 3.Seek for technical support
10	Err.10	Inverter overload	1.The type selection of inverter is small 2.Whether the load is too large or the motor stall occurs	1.Choose the inverter with large power level 2.Reduce the load and check the motor and its mechanical conditions
11	Err.11	Motor Overload	1. power grid voltage is too low 2.Whether the setting motor protection parameters (F8.03) is appropriate or not 3.Whether the load is too large or the motor stall occurs	1.Check the power grid voltage 2.Correctly set this parameter. 3.Reduce the load and check the motor and its mechanical conditions
13	Err.13	Output phase loss	1.The lead wires from the inverter to the motor is not normal 2.The inverter's three phase output is unbalanced when the motor is running 3.The drive panel is abnormal. 4.The module is abnormal	1.Eliminate peripheral faults 2.Check the motor's three-phase winding is normal or not and eliminate faults 3.Seek for technical support
14	Err.14	Module overheating	1.The air duct is blocked 2.The fan is damaged 3.The ambient temperature is too high 4.The module thermistor is damaged 5.The inverter module is damaged	1.Clean up the air duct 2.Replace the fan 3.Decrease the ambient temperature 4.Replace the thermistor 5.Replace the inverter module
15	Err.15	External equipment fault	Input external fault signal through the multi-function terminal DI	Reset run
16	Err.16	Communication fault	1.The communication cable is not normal 2.The settings for communication expansion card F9.07 are incorrect 3.The settings for communication parameters F9 group are incorrect 4.The host computer is not working properly	1.Check the communication cable 2.Correctly set the communications expansion card type 3.Correctly set the communication parameters 4.Check the wiring of host computer
17	Err.17	Contact fault	1.Input phase loss 2.The drive plate and the contact are not normal	1.Check and eliminate the existing problems in the peripheral line 2.Replace the drive, the power board or contactor
18	Err.18	Current detection fault	1.Check hall device 2.The drive panel is abnormal.	1.Replace the drive panel 2.Replace hall device
19	Err.19	Motor parameter auto tuning fault	1.The motor parameters was not set according to the nameplate 2.The identification process of parameter is timeout	1.Correctly set motor parameter according to the nameplate 2.Check the lead wire from the inverter to the motor
21	Err.21	EEPROM read and write fault	EEPROM chip is damaged	Replace the main control panel
22	Err.22	Inverter hardware fault	1.Overvoltage 2.Overcurrent	1.Eliminate overvoltage fault 2.Eliminate overcurrent fault
23	Err.23	Short-circuit to ground fault	Motor short to ground	Replace the cable or motor
26	Err.26	Cumulative running time arrival fault	Cumulative running time arrival fault	Clear history information by using initialization function parameters
27	Err.27	Custom fault 1	Input custom fault 1 signal through the multi-function terminal DI	Reset run
28	Err.28	Custom fault 2	Input custom fault 2 signal through the multi-function terminal DI	Reset run
29	Err.29	Total power-on time arrival fault	Total power-on time reaches the set value	Clear history information by using initialization function parameters
31	Err.31	PID feedback loss when running fault	PID feedback is less than the set value of E2.11	Check PID feedback signal or set E2.11 to an appropriate value
40	Err.40	Quick current limiting fault	1.Whether the load is too large or the motor stall occurs 2.The type selection of inverter is small	1.Reduce the load and check the motor and its mechanical conditions 2.Choose the inverter with large power level
41	Err.41	Switch motor when running fault	Change current motor through the terminal when the inverter is running	Switch motor after the inverter stops
42	Err.42	Too large speed deviation fault	1.The setting for Too Large Speed Deviation parameters(F8.15, F8.16) is unreasonable. 2.The setting for encoder parameters is incorrect 3.The parameter was not identified	1.Reasonably set the detection parameters 2.Correctly set encoder parameters 3.Perform identification for the motor parameters
51	Err.51	Initial position error	The deviation between the motor parameters and the actual	Reconfirm the correct motor parameters, focus on whether

No.	Fault ID	Failure type	Possible causes	Solutions
			parameters is too large	the rated current is set to too small.
-	COF	Communication failure	1.Keyboard interface control board interface; 2.Keyboard or crystal connector; 3.Control board or keyboard hardware damage; 4.Keyboard line is too long, causing the interference.	1.Detection of keyboard interface, control board interface is abnormal. 2.Detect keyboard, crystal joints are abnormal. 3.Replace control board or keyboard. 4.Consult factory, seek help.

Appendix: Dimension drawing of PI550A-S keyboard installation opening (dimension unit: mm):

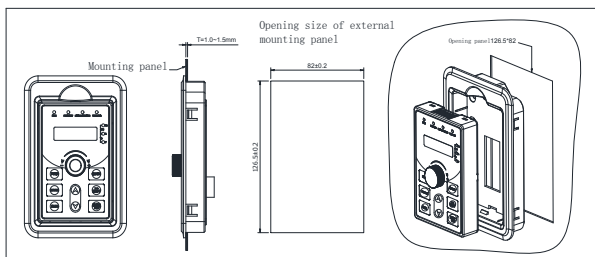

Powtran technology

A manufacturer of motor control intelligent products and devices based on motor design.

Contact

Dalian Powtran Technology Co.,Ltd.

Address: No.11 Renxian Street, Qixianling,
 Hitech Industrial Zone, Dalian, China(116023)
 Tel: 0411-84820088 84821133
 Fax: 0411-84821978 84821878
 Email: info@powtran.com
 Website: www.powtran.com

Guangdong Powtran Power Electronics Co.,Ltd.

Address: Room 1301, Building 28, No. 179, Fenggang Section, Dongsh
 en Road Fenggang Town, Dongguan city, Guangdong Province, China.
 Tel: 0769-22222279
 Fax: 0769-22222279
 Email: powtran@powtran.com
 Website: www.powtran.com

Hotline:

086-755-29630738

Content changes due to continuous upgrade of our products are subject to change without notice.

Copyright ©Dalian Powtran Technology Co.,Ltd.

